

Extreme™ Series



MARINE PRODUCT DATA SHEET

OEM: 4901-1201
AFTERMARKET: 4901-1211

The Smart Sensor 4.0 is designed specifically for cruisers and midsize yachts. Delivering 4.0 GPM and pressure up to 50 PSI, this micro-controller based variable speed pump precisely monitors your system's water pressure and adjusts the motor speed, eliminating the need for an accumulator tank.

TYPICAL APPLICATIONS

Multi-fixture marine potable water installations. Other uses may include 24V DC pressurized water systems in cabins. This pump may be used for general water transfer. For other applications, contact SHURflo.

PUMP

Type: 4 Chamber Diaphragm
 Ports: 1/2"-14 NPSM-Male.
 Liquid: 130 °F [54 °C] Max
 Prime: 6 feet [1.82 M]
 Inlet PSI: 30 PSI [2.1 Bar] Max
 Run Dry: Yes

ELECTRICAL

Motor: 24VDC Permanent Magnet, Intermittent Duty
 Protection: Thermal Overload, Automatic Restart
 Leads: 16 AWG, 16" [40 cm] Red +, 13" [33 cm] Black -
 Fuse: 7.5 Amp Recommended
 Control: Shut-Off 60 PSI [4.1 Bar] ± 5 PSI [0.4 Bar]
 Restart 30 PSI [2.0 Bar] ± 5 PSI [0.4 Bar]

MATERIALS

Housing: Nylon
 Valves: EPDM
 Diaphragm: Santoprene
 Hardware: Stainless Steel

APPROVALS

Ignition Protected, CE, ISO 8846

WARRANTY

3 Year Limited Warranty
 See SB-1041 & SB-1050 For Full Warranty Details

SHIPPING

Net Weight (Boxed): Lb [Kg] each
 Carton Weight: 6 each, 42 Lb [19 Kg]
 Carton Size: 24"L x 18"W x 6"H
 [61 cm x 46 cm x 15 cm]

RELATED DOCUMENTS

Catalog: MS-030-140
 Installation Manual: 911-713
 Maintenance: 911-713
 Applications Spec Guide: MS-020-005
 Warranty: SB-1050

Replacement Kits

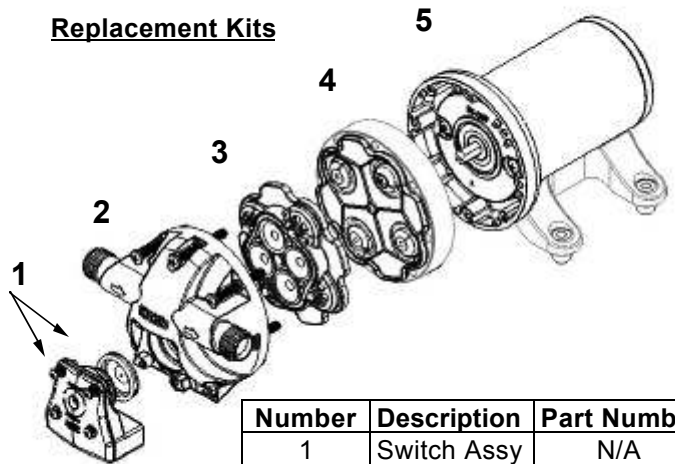

Number	Description	Part Number
1	Switch Assy	N/A
2	Upper Hsg	N/A
3	Valve Assy	94-030-11
4	Drive Assy	94-030-12
5	Motor	N/A



PERFORMANCE @ 24V DC

PRESSURE		FLOW		CURRENT
BAR	PSI	GPM	LPM	AMPS
0.0	0	4.0	15.1	2.0
0.7	10	2.9	10.9	2.6
1.4	20	2.6	9.8	3.2
2.1	30	2.3	8.7	3.6
2.8	40	2.0	7.5	3.7

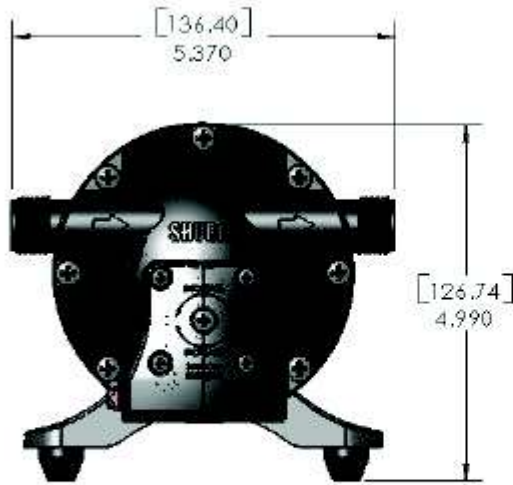
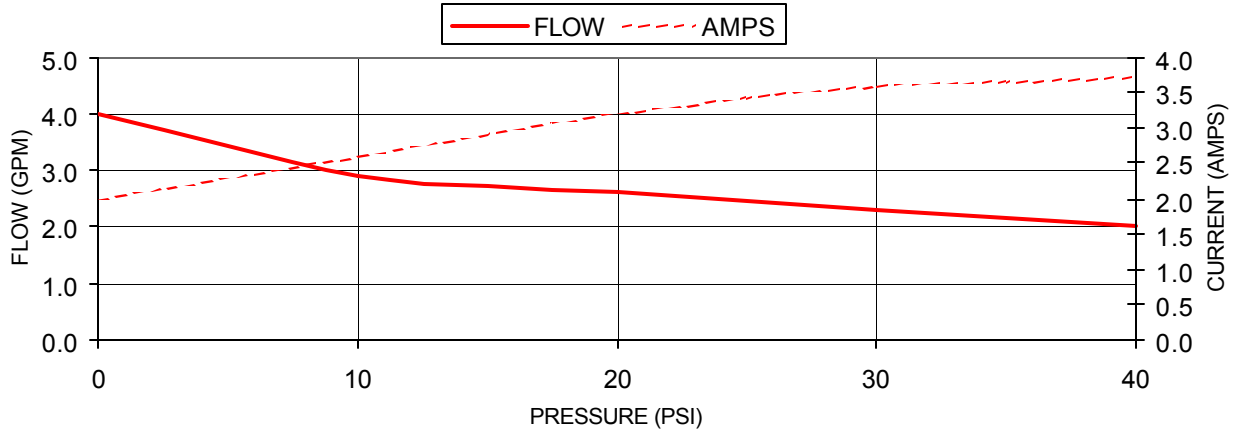

DIMENSIONS [mm]

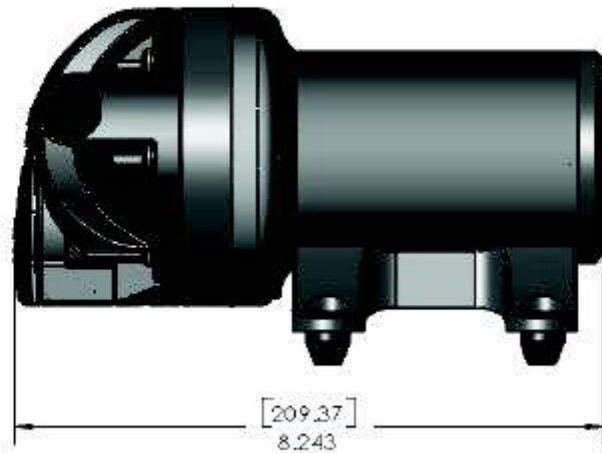

*ISO Registered Facility *SHURflo reserves the right to update specifications, prices, or make substitutions.*

SHURflo *
 5900A Katella Ave.
 Cypress, Ca. 90630
 (800) 854-3218 (562) 795-5200
 FAX (562) 795-7554
 Shipping/UPS: 5900C Katella Ave.
 Cypress, Ca. 90630

SHURflo East
 52748 Park Six Court
 Elkhart, IN 46514-5427
 (800) 762-809 (574) 262-0478
 FAX (574) 264-2169
 Http://www.shurflo.com
 ©2001

SHURflo Ltd. *
 Unit 5 Sterling Park
 Gatwick Road, Crawley
 West Sussex, RH10 2QT
 United Kingdom
 +44 1293 424000
 FAX +44 1293 421880

