

SPECIFICATIONS:

- MODEL NUMBER:** 8000-533-236
- PUMP DESIGN:** Positive Displacement 3 Chamber Diaphragm Pump
- CHECK VALVE:** (2-Way Op.) Prevents Reverse Flow & 6 Ft. Head Forward Flow
- CAM:** 3.0 Degree
- MOTOR:** Permanent Magnet, P/N 11-150-00, Thermally Protected
- VOLTAGE:** 115 VAC Nominal
- PRESSURE SWITCH:** Adjustable Shut-Off (Range 40-60 PSI)
 Factory Set @ 60 PSI, Turn On 45 PSI ± 5 PSI
- LIQUID TEMPERATURE:** 170 Degrees Fahrenheit (77 Degrees Centigrade) Max.
- PRIME:** Self-Priming Up To 8.0 Ft. Vertical,
 Max. Inlet Pressure 30 PSI (2.1 Bar)
- PORTS:** 3/8"-18 NPT Female
- MATERIAL OF CONSTRUCTION:**
 - PLASTICS-** Polypropylene
 - VALVES-** Viton
 - DIAPHRAGM-** Santoprene
 - FASTENERS-** Zinc Plated Steel
- NET WEIGHT:** 3.8 Lbs (1.72 Kg)
- DUTY CYCLE:** Intermittent (See Temperature Rise Chart)
- APPROVALS:** UL/CSA Recognized Component
- TYPICAL APPLICATIONS:** Soil Extraction

DIMENSIONS:

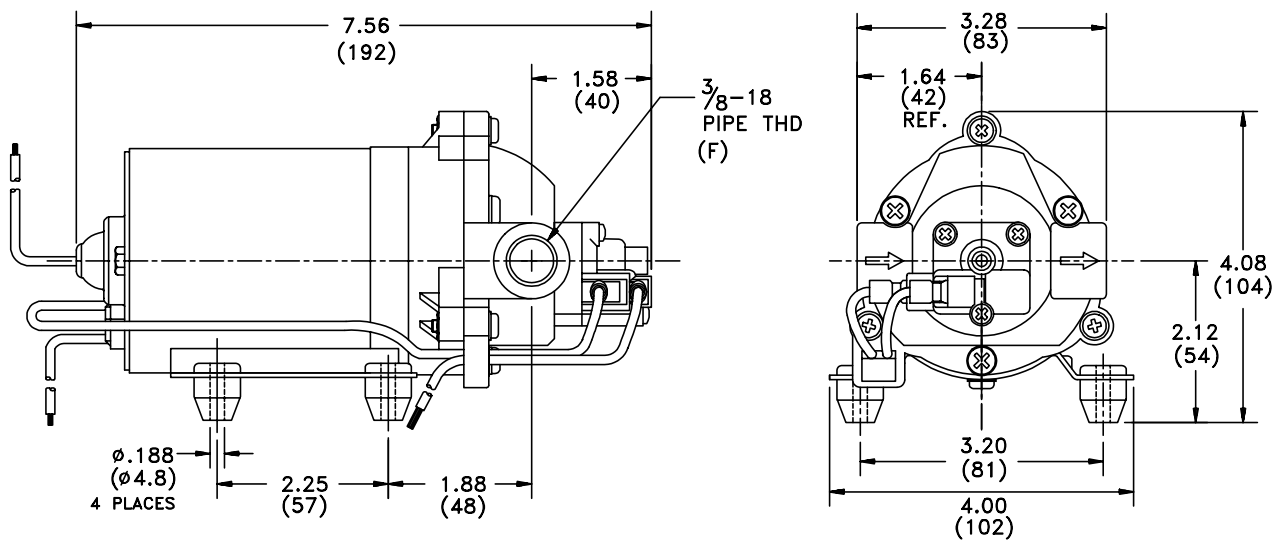

TEMPERATURE RISE

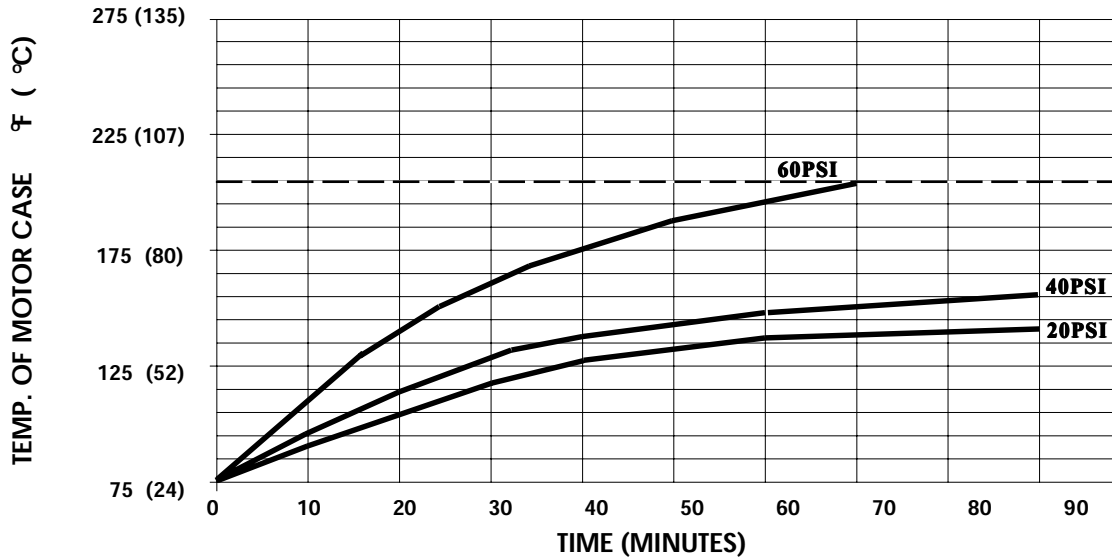

THIS GRAPH IS FOR USE AS A DESIGN GUIDE. IT IS BASED ON RUNNING CONTINUOUSLY WITH AN AMBIENT TEMPERATURE OF 75° F IN STILL AIR. THE THERMAL BREAKER WILL OPEN WHEN THE CASE TEMPERATURE REACHES 203° F.

[----- TRIP POINT OF THERMAL PROTECTOR]

TYPICAL PERFORMANCE

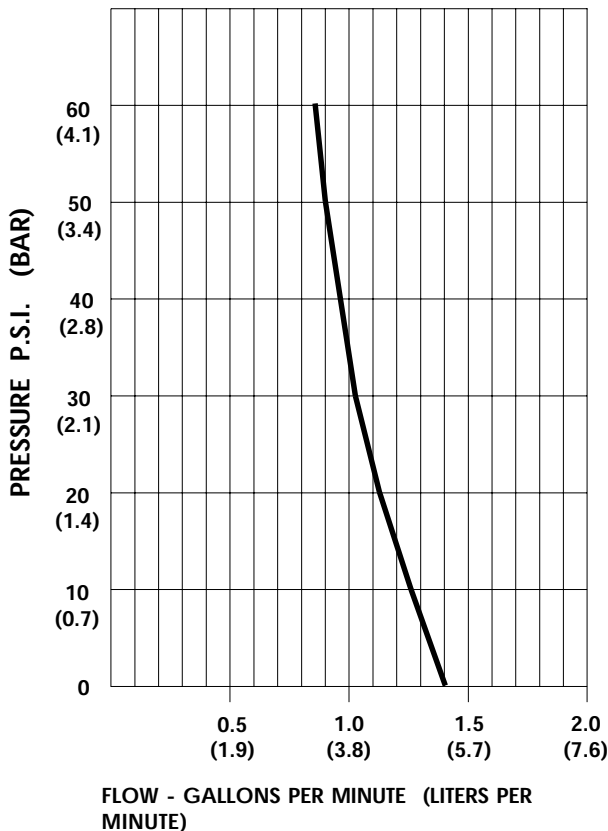

PRESSURE (PSI)	FLOW (GPM/LIT)	RPM MIN/MAX	CURRENT (AMPS)	VOLTAGE (VOLTS)
OPEN	1.39/5.3	2160/2170	0.35	115VAC
10	1.26/4.8	2005/2035	0.41	"
20	1.15/4.3	1880/1910	0.46	"
30	1.05/4.0	1770/1820	0.51	"
40	0.97/3.7	1660/1730	0.55	"
50	0.91/3.4	1570/1645	0.60	"
60	0.85/3.2	1510/1575	0.64	"

-SPECIFICATIONS SUBJECT TO CHANGE WITHOUT NOTICE.

-ALL DATA BASED ON TESTING WITH WATER AT AMBIENT TEMPERATURE.