

SPECIFICATIONS:

MODEL NUMBER: 8020-833-238

PUMP DESIGN: Positive Displacement 3 Chamber Diaphragm Pump

CHECK VALVE: (2-Way Op.) Prevents Reverse Flow & 6Ft. Head Forward Flow

CAM: 3.0 Degree

MOTOR: Permanent Magnet, P/N 11-195-01, Thermally Protected

VOLTAGE: 115 VAC Nominal

PRESSURE SWITCH: Adjustable Shut-Off (Range 80-100 PSI)

Factory Set @ 95 PSI, Turn On 75 PSI \pm 5 PSI

LIQUID TEMPERATURE: 180 Degrees Fahrenheit (82 Degrees Centigrade) Max.

PRIME: Self-Priming Up To 12 Ft. Vertical,
Max. Inlet Pressure 30 PSI (2.1 Bar)

PORTS: 3/8"-18 NPT Female

MATERIAL OF CONSTRUCTION:

PLASTICS- Nylon

VALVES- Viton

DIAPHRAGM- Santoprene

FASTENERS- Zinc Plated Steel

NET WEIGHT: 5.3 Lbs (2.4 Kg)

DUTY CYCLE: Intermittent (See Temperature Rise Chart)

APPROVALS: UL/CSA Listed

TYPICAL APPLICATIONS: Soil Extraction, Water Delivery

DIMENSIONS:

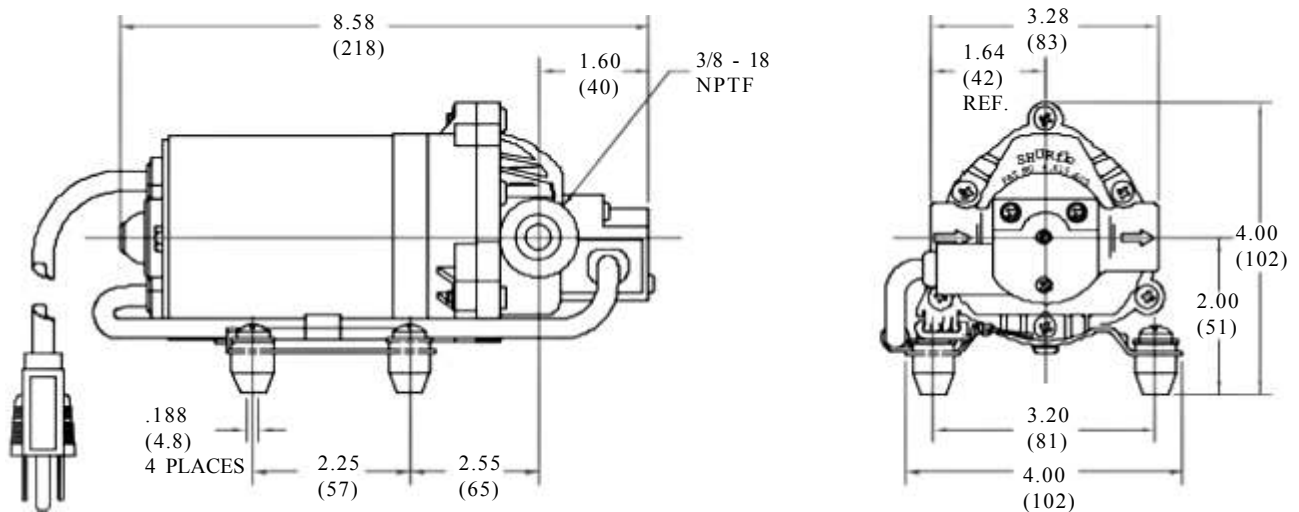

TEMPERATURE RISE

MODEL: 8020-833-238

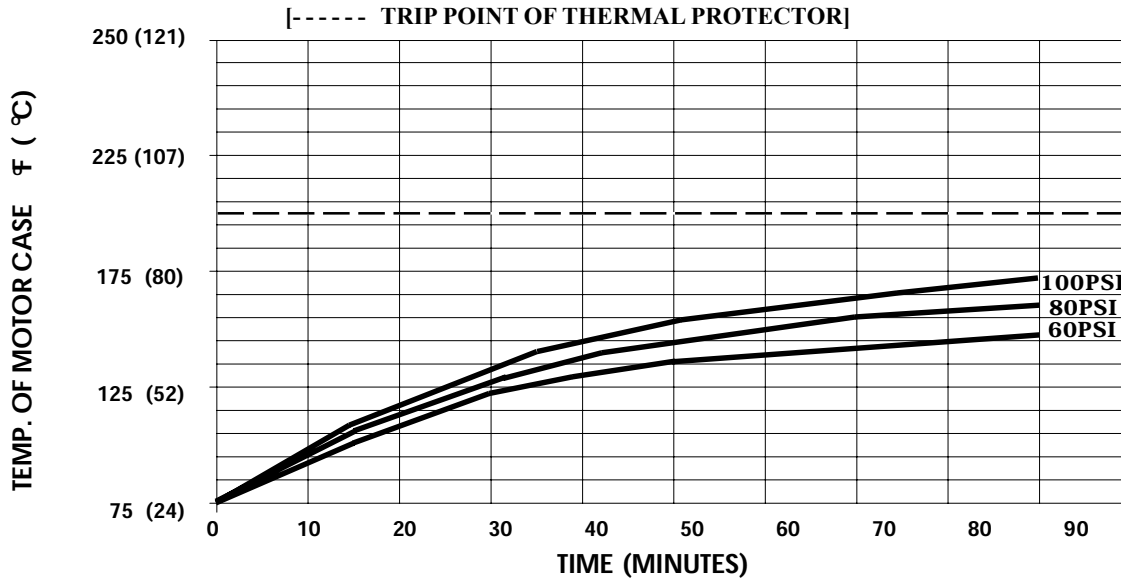

THIS GRAPH IS FOR USE AS A DESIGN GUIDE. IT IS BASED ON RUNNING CONTINUOUSLY WITH AN AMBIENT TEMPERATURE OF 75 ° F IN STILL AIR. THE THERMAL BREAKER WILL OPEN WHEN THE CASE TEMPERATURE REACHES 203 ° F.

-SPECIFICATIONS SUBJECT TO CHANGE WITHOUT NOTICE.

-ALL DATA BASED ON TESTING WITH WATER AT AMBIENT TEMPERATURE.

TYPICAL PERFORMANCE

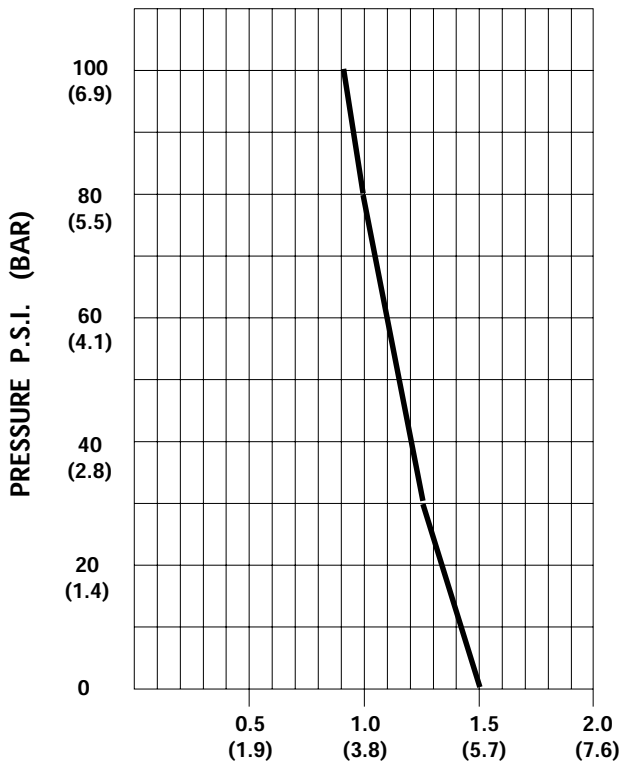

PRESSURE (PSI)	FLOW (GPM/LIT)	RPM MIN/MAX	CURRENT (AMPS)	VOLTAGE (VOLTS)
OPEN	1.50/5.7	2065/2190	0.33	115VAC
10	1.41/5.3	2010/2135	0.38	"
20	1.32/5.0	1930/2055	0.45	"
30	1.25/4.7	1865/1980	0.52	"
40	1.14/4.3	1800/1910	0.58	"
50	1.12/4.2	1750/1840	0.64	"
60	1.07/4.0	1700/1795	0.70	"
70	1.03/3.9	1635/1740	0.76	"
80	0.97/3.7	1590/1680	0.82	"
90	0.93/3.5	1540/1630	0.93	"
100	0.91/3.4	1500/1570	0.95	"

FLOW - GALLONS PER MINUTE (LITERS PER MINUTE)