

**SPECIFICATIONS:**

**MODEL NUMBER:** 8090-801-248

**PUMP DESIGN:** Positive Displacement 3 Chamber Diaphragm Pump

**CHECK VALVE:** (2-Way Op.) Prevents Reverse Flow & 6 Ft. Head Forward Flow

**CAM:** 2.0 Degree

**MOTOR:** Permanent Magnet, P/N 11-160-10, Thermally Protected

**VOLTAGE:** 230 VAC Nominal

**PRESSURE SWITCH:** Adjustable Shut-Off (Range 80-100 PSI)

Factory Set @ 100 PSI, Turn On 85 PSI ± 5 PSI

**LIQUID TEMPERATURE:** 180 Degrees Fahrenheit (82 Degrees Centigrade) Max.

**PRIME:** Self-Priming Up To 4 Ft. Vertical,  
Max. Inlet Pressure 30 PSI (2.1 Bar)

**PORTS:** 3/8"-18 NPT Female

**MATERIAL OF CONSTRUCTION:**

**PLASTICS-** Nylon

**VALVES-** Viton

**DIAPHRAGM-** Santoprene

**FASTENERS-** Zinc Plated Steel

**NET WEIGHT:** 4.8 Lbs (2.18 Kg)

**DUTY CYCLE:** Intermittent (See Temperature Rise Chart)

**TYPICAL APPLICATIONS:** Soil Extraction

**APPROVALS:** VDE Approved

**DIMENSIONS:**

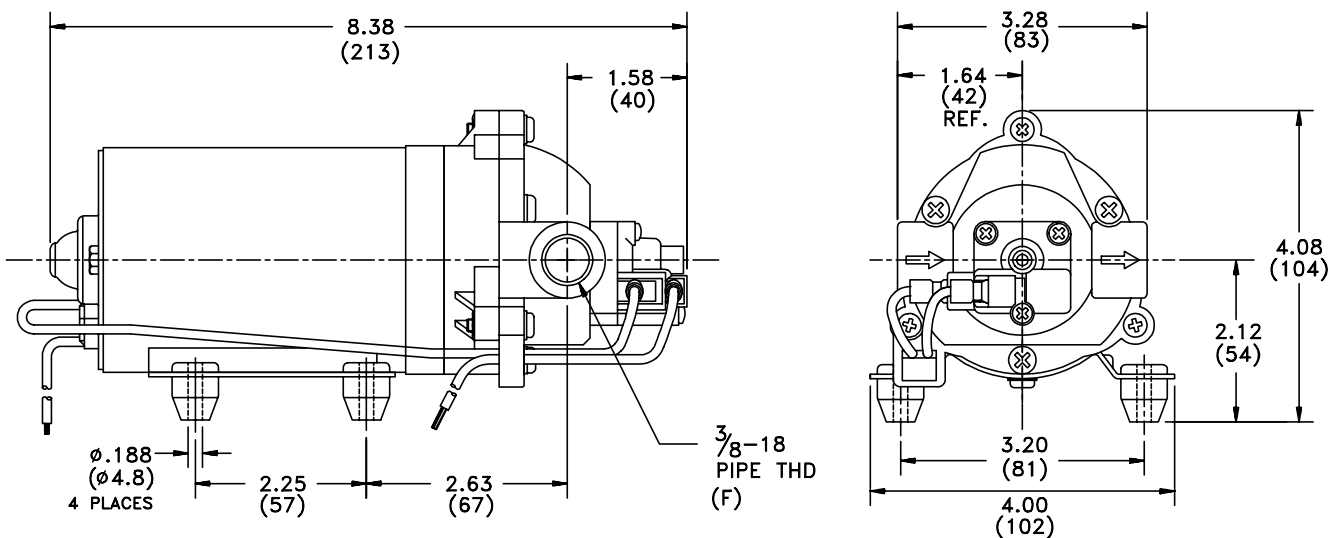

# TEMPERATURE RISE

MODEL: 8090-801-248

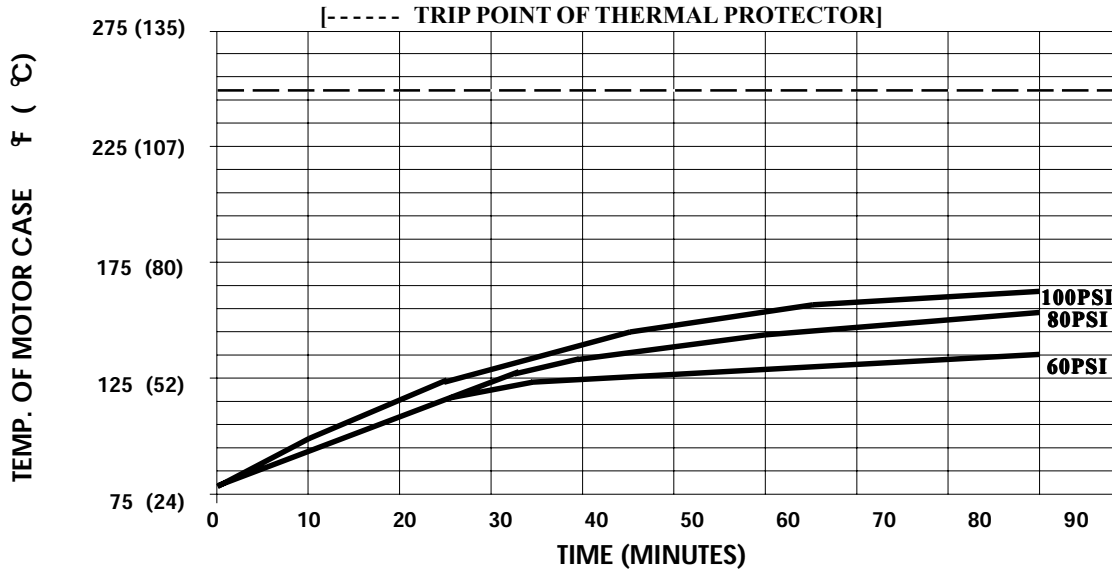

THIS GRAPH IS FOR USE AS A DESIGN GUIDE. IT IS BASED ON RUNNING CONTINUOUSLY WITH AN AMBIENT TEMPERATURE OF 80° F IN STILL AIR. THE THERMAL BREAKER WILL OPEN WHEN THE CASE TEMPERATURE REACHES 250° F.

# TYPICAL PERFORMANCE

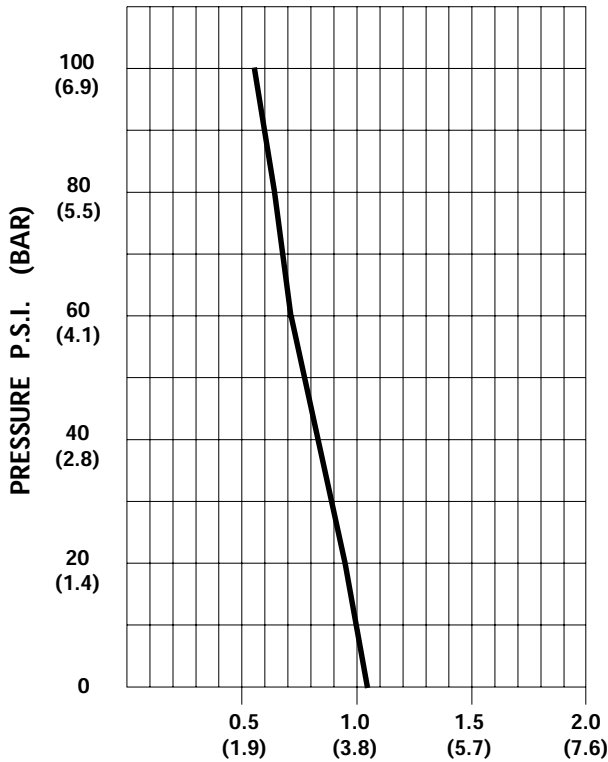

PRESSURE (PSI)	FLOW (GPM/LIT)	RPM MIN/MAX	CURRENT (AMPS)	VOLTAGE (VOLTS)
OPEN	1.11/4.2	2545/2570	0.15	230VAC
10	1.05/4.0	2505/2530	0.17	"
20	0.95/3.6	2440/2455	0.20	"
30	0.88/3.3	2370/2390	0.21	"
40	0.82/3.1	2315/2330	0.23	"
50	0.76/2.9	2260/2270	0.25	"
60	0.71/2.7	2220/2230	0.26	"
70	0.66/2.5	2180/2190	0.27	"
80	0.63/2.4	2145/2155	0.29	"
90	0.59/2.2	2105/2110	0.30	"
100	0.54/2.0	2045/2070	0.31	"

FLOW - GALLONS PER MINUTE (LITERS PER MINUTE)

*-SPECIFICATIONS SUBJECT TO CHANGE WITHOUT NOTICE.*

*-ALL DATA BASED ON TESTING WITH WATER AT AMBIENT TEMPERATURE.*