

SPECIFICATIONS:

MODEL NUMBER: 8000-541-236

PUMP DESIGN: Positive Displacement 3 Chamber Diaphragm Pump

CHECK VALVE: (1-Way Operation) Prevents Reverse Flow

CAM: 2.0 Degree

MOTOR: Permanent Magnet, P/N 11-148-04, Thermally Protected

VOLTAGE: 12 VDC Nominal

PRESSURE SWITCH: Adjustable Shut-Off (Range 40-60 PSI)

Factory Set @ 60 PSI, Turn On 45 PSI \pm 5 PSI

LIQUID TEMPERATURE: 170 Degrees Fahrenheit (77 Degrees Centigrade) Max.

PRIME: Self-Priming Up To 11 Ft. Vertical,
Max. Inlet Pressure 30 PSI (2.1 Bar)

PORTS: 3/8"-18 NPT Female

MATERIAL OF CONSTRUCTION:

PLASTICS- Polypropylene

VALVES- Viton

DIAPHRAGM- Santoprene

FASTENERS- Zinc Plated Steel

NET WEIGHT: 3.78 Lbs (1.71 Kg)

DUTY CYCLE: Intermittent (See Temperature Rise Chart)

TYPICAL APPLICATIONS: Agricultural Spraying

DIMENSIONS:

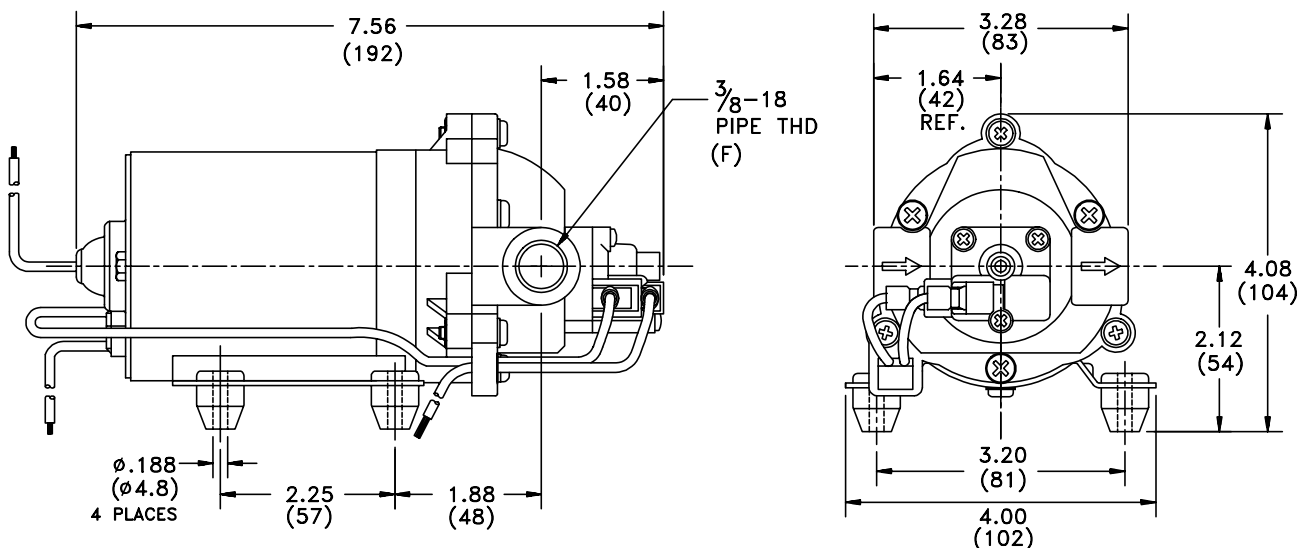

TEMPERATURE RISE

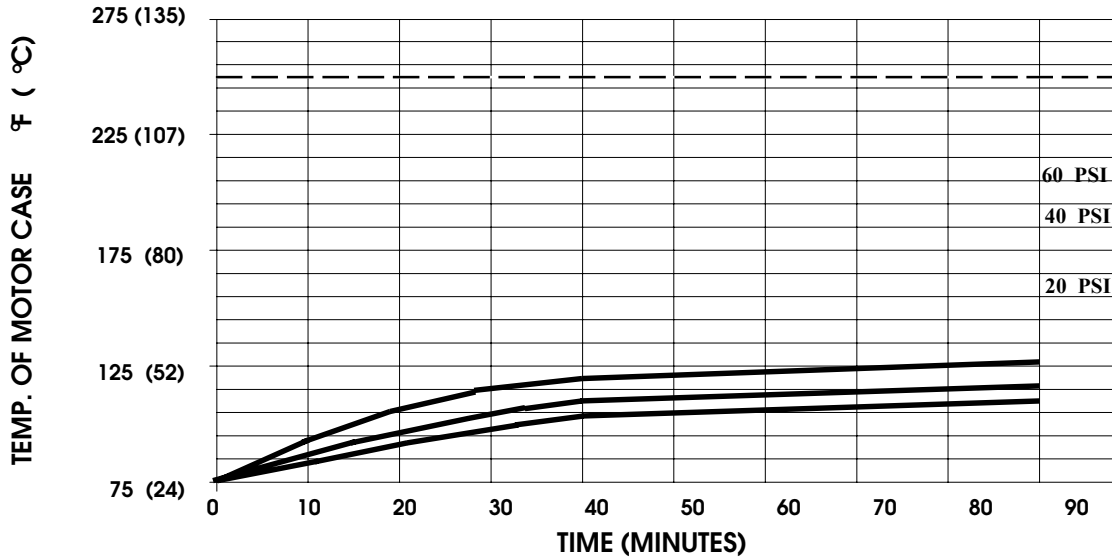

THIS GRAPH IS FOR USE AS A DESIGN GUIDE. IT IS BASED ON RUNNING CONTINUOUSLY WITH AN AMBIENT TEMPERATURE OF 75°F IN STILL AIR. THE THERMAL BREAKER WILL OPEN WHEN THE CASE TEMPERATURE REACHES 250° F.

[----- TRIP POINT OF THERMAL PROTECTOR]

TYPICAL PERFORMANCE

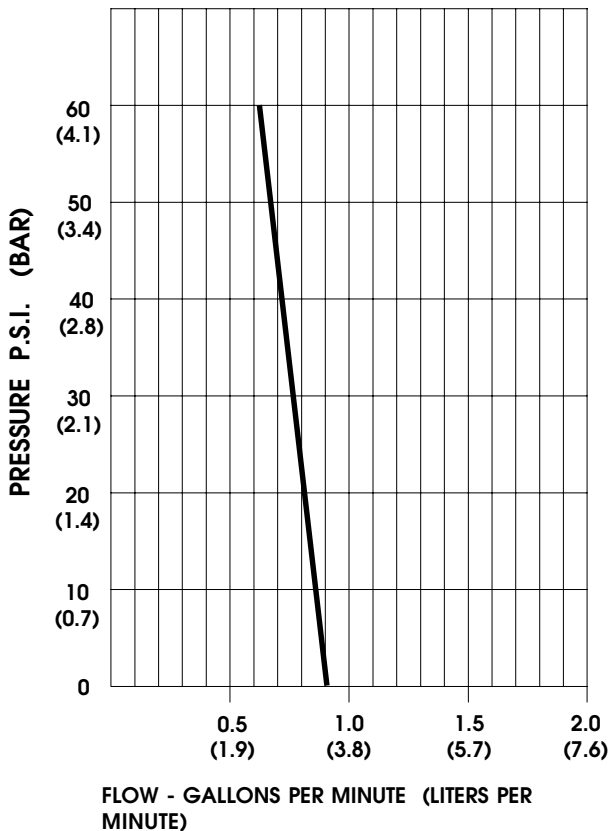

PRESSURE (PSI)	FLOW (GPM/LIT)	RPM MIN/MAX	CURRENT (AMPS)	VOLTAGE (VOLTS)
OPEN	0.89/3.4	1935/1945	1.5	12 VDC
10	0.87/3.3	1885/1900	1.9	"
20	0.79/3.0	1840/1855	2.3	"
30	0.75/2.8	1780/1810	2.8	"
40	0.70/2.6	1735/1760	3.2	"
50	0.65/2.5	1690/1735	3.5	"
60	0.62/2.3	1665/1715	3.8	"

-SPECIFICATIONS SUBJECT TO CHANGE WITHOUT NOTICE.

-ALL DATA BASED ON TESTING WITH WATER AT AMBIENT TEMPERATURE.